



**SECTIONAL OVERHEAD INDUSTRIAL DOOR**

**SIN501** LOW LIFT, PASSAGE DOOR, STANDARD COLOUR

version05

**General information**

Sectional overhead doors manufactured in AS Saku Metall open vertically and move along guide rails up under the ceiling. Construction of sectional door needs little space and seals in edges ensure weather-resistance of door and minimum heat losses. Sections have special shape, making it impossible to crush fingers with the panel when closing the door. Industrial sectional door is suitable for use in industrial buildings and commercial facilities. It is not recommended to install the door into humid or chemically active environment.

**Dimensions**

Construction aperture: width (B) <5000; height (H) <4000  
 Lintel height (h): >240 (spring behind)  
 Dimensions of light aperture = dimensions of construction aperture  
 Light aperture of passage door: **900 x 1860**  
 Height of door sheet: >2180  
 Thickness of door sheet: **40**  
 Free lateral space (PL\*): >150

**Door sheet**

Door sheet consists of 40 mm thick heat-insulated sections, with finger pinch protection. Insulation is thick freon-free polyurethane foam, surrounded with aluminium or galvanized steel sheet. Steel sections are painted with weather-proof polyester paint. Standard tones of door of steel sections – internal side white RAL 9010, external side white RAL 9010, dark brown RAL 8014 or silver RAL 9006. Aluminium sections are made of non-painted natural aluminium. Additional reinforcement: horizontal sheet metal stripes in upper and lower edges of internal side, to which connection hinges of sections are fixed. Heat transfer coefficient of sections  $U = 1,0 \text{ W}/(\text{m}^2 \cdot ^\circ\text{C})$ .

**Control system**

Guide rail system is installed to internal side of door aperture, which is made of galvanized 2,0mm steel profiles and along which door sections move up and down with the help of rolls. Low lift is ideal for industrial and production buildings where the lintel height is 240-450 mm.

**Balancing**

High-quality torsion spring is used for balancing of door sheet. Standard life is 15000 cycles, but torsion springs with up to 100 000 cycles can be ordered. All torsion springs are equipped with protectors against breakdown of springs. All torsion springs have spring break protectors and in order to ensure better safety, wire break protectors are included with 18 m<sup>2</sup> doors.

**Sealing**

EPDM rubber is used in upper and lower edge of door to increase air tightness of door. Sides are sealed with special gasket made of mix of PVC and rubber (TPR). Seals are also in connection points of sections.

**Passage door**

Passage door with overall dimensions 1030 x 1965 and illuminating surface with dimensions 900 x 1860 have been made of aluminium profiles and sealed with EPDM seal. You can get additional information about the closures for passage doors from the seller.

**Maintenance**

Depending on the usage intensity of the door, a specialist with appropriate training must service the door after every 1,800 cycles. This must be done at least once per year – the usage life of the door will be significantly longer this way. It is possible to sign a maintenance contract upon purchasing the door.

**Accessories**

Following accessories can be installed to the door:

- Plastic windows
- Ventilation grids
- Automatic system
- Manual chain drive
- External lock

**Conformance to the standard**

Sectional overhead industrial door with low lift meets the harmonized product standard EN 13241-1:2005+A1:2011.

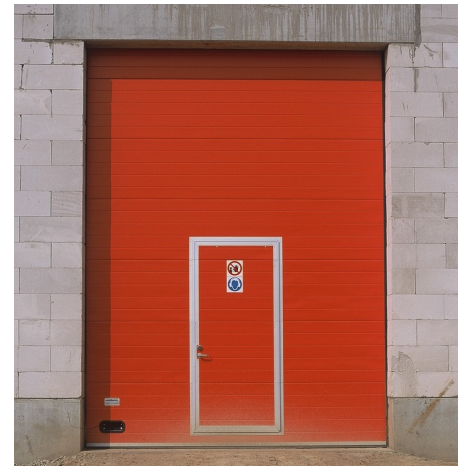

**vertical section**

$P = H + 1000$

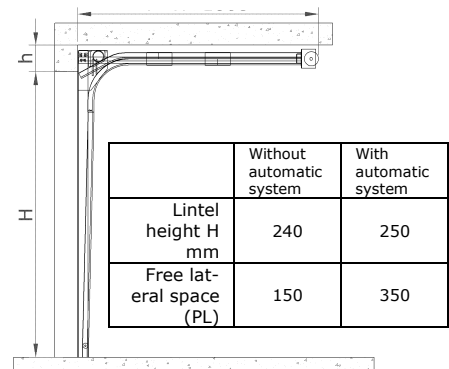

**horizontal section**

